



**INSTALLATION INSTRUCTIONS**

Congratulations—your new Work-Rite load assists are quality products capable of improving the handling and comfort of your vehicle while under load. As with all products, proper installation is the key to obtaining all of the benefits your kit is capable of delivering. Please take a few minutes to read through the instructions to identify the components and learn where and how they are used. It is a good idea to start by comparing the parts in your kit with the parts list below.

**NOTE: IF ANY PARTS ARE MISSING FROM THE KIT, PLEASE CALL 1-800-888-0650. PLEASE DO NOT CALL OR RETURN THE KIT TO THE DEALER.**

Be sure to take all applicable safety precautions during the installation of the kit. The instructions listed in this brochure and the illustrations all show the left, or driver’s side of the vehicle. To install the right side assembly simply follow the same procedures.

**STEP 1—PREPARE THE VEHICLE**

With the vehicle on a solid, level surface chock the front wheels. Remove the negative battery cable. Remove the jounce bumpers located under the frame rail, by removing the bolt located inside the bumper. The jounce bumpers and bolts will not be re-used with this kit.

**STEP 2—PRE-ASSEMBLE THE KIT**

**1999-2007:** Select one Work-Rite load assist from your kit. Insert a M10 x 40MM bolt, lock washer, and flat washer through the bottom of the Work-Rite and into the small hole in the top. Place the support disk over the bolt. Insert the bolt into the existing hole from the jounce bumper removal and secure with a M10 nut and flat washer. **See Figure “A”.**

**2008-CURRENT:** Select one Work-Rite load assist from your kit. Insert a M10 x 40MM bolt, lock washer, and flat washer through the bottom of the Work-Rite and into the small hole in the top. Place the support disk over the bolt. Fasten the Work-Rite and disk to the frame. **See Figure “B”.**

**NOTE:** An optional spacer may be installed to engage the Work-Rite sooner when a load is applied. To install, place between the Work-Rite and the support disk. If the spacers are installed, use the M10 x 65MM bolt instead of the M10 x 40MM bolt. There should be 1/4" to 3/8" between the Work-Rite and the axle. **See Figure “C”.**

**STEP 3—FINISH UP**

Remove the wheel chocks and reconnect the battery cable. Now you're finished and ready to put your Work-Rite to use!

**PARTS LIST**

WORK-RITE LOAD ASSISTS	1259	2	M10 FLANGE NUT	2
SUPPORT DISK	5229	2	FLAT WASHER	2
OPTIONAL SPACERS	0013	4	LOCK WASHER	2
M10 X 40MM HEX BOLT		2		
M10 X 65MM HEX BOLT		2		

FIGURE "A"

1999-2007

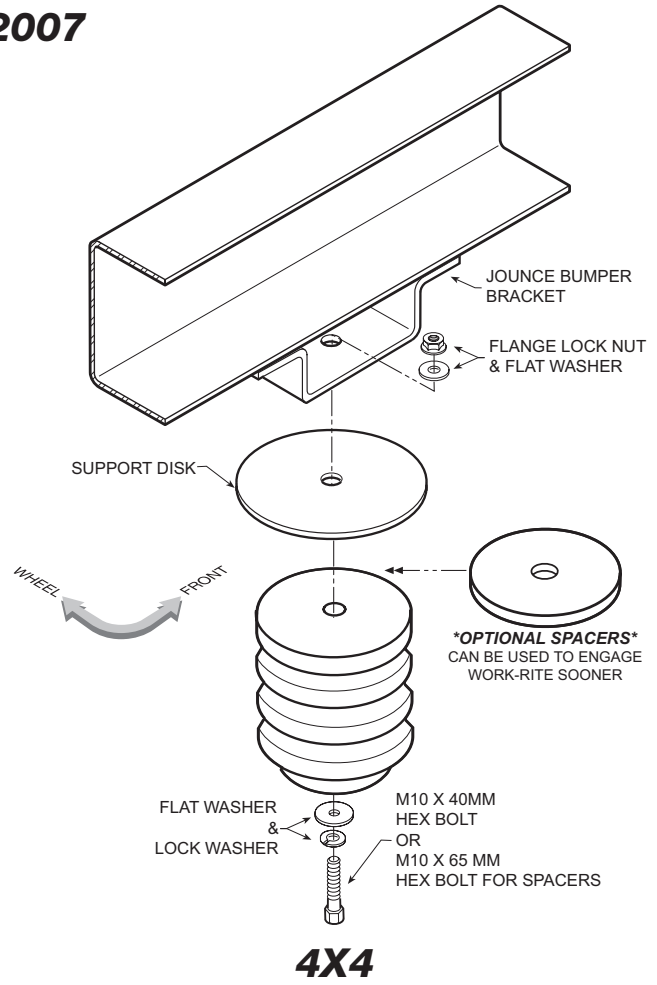
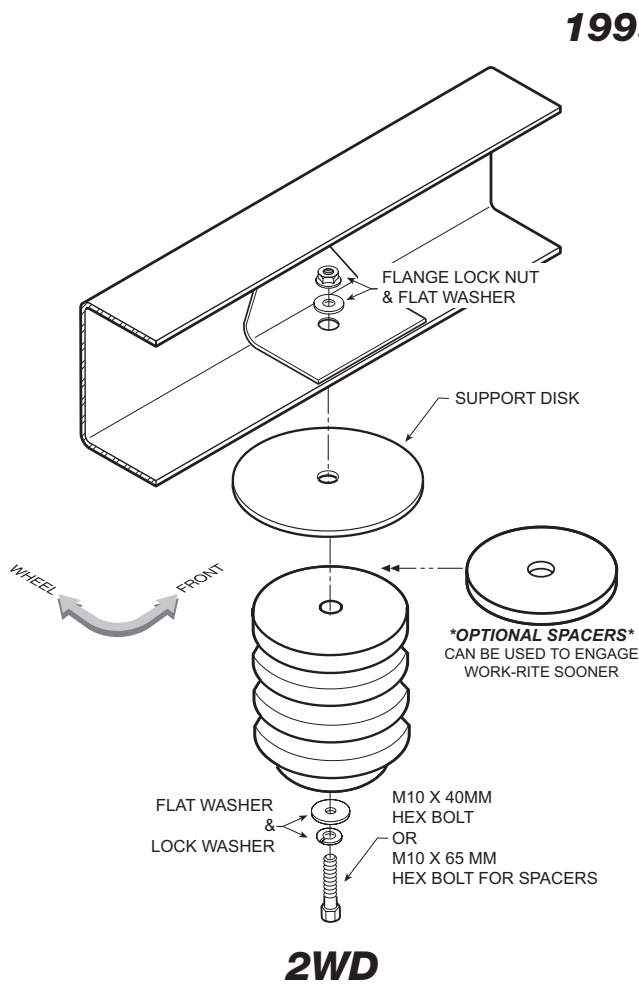

FIGURE "B"

2008-CURRENT

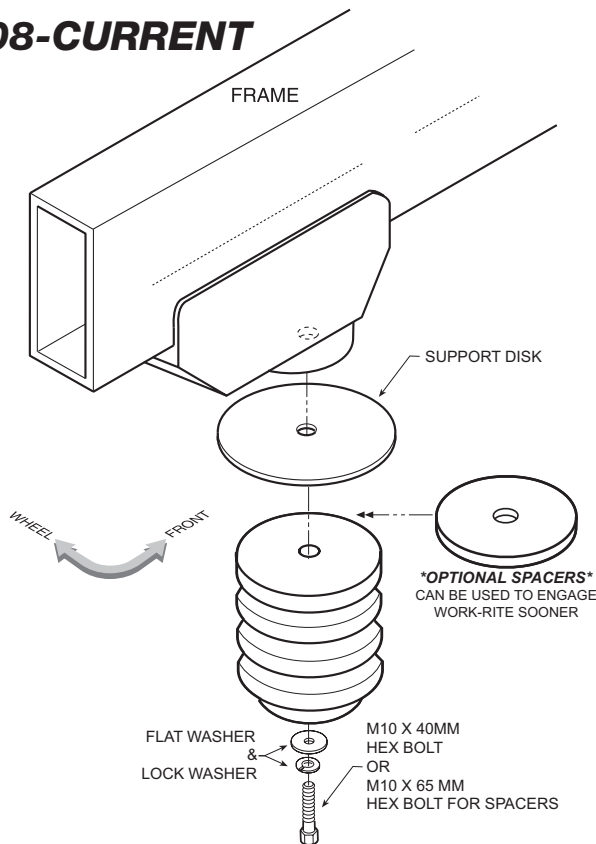
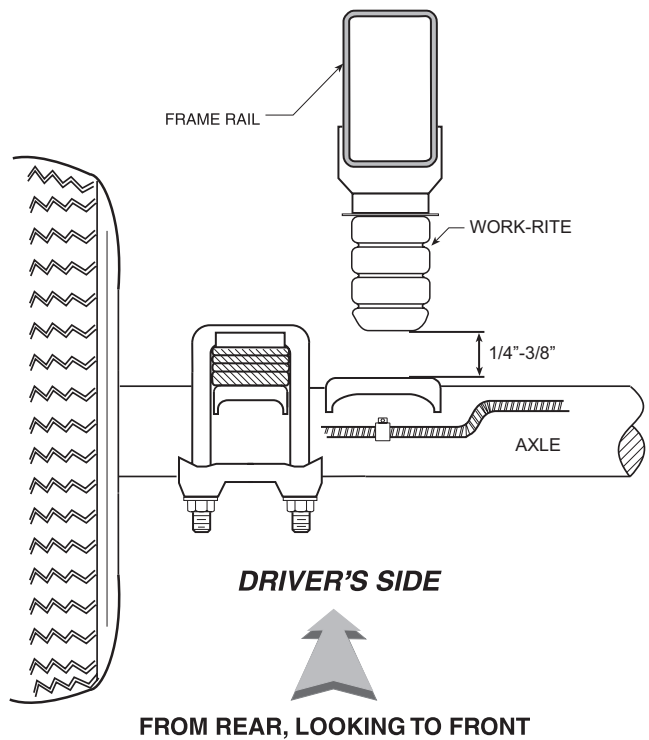

FIGURE "C"





# Do Not Return This Product to the Dealer or Distributor

## If you are

- missing parts,
- experiencing installation problems, or
- have technical concerns regarding this product,

you may contact a Firestone Technical Service Representative at [rrtech@fsip.com](mailto:rrtech@fsip.com) or at 800-888-0650 (option 1, and then option 2). Representatives are available from 7:30 a.m. – 4:30 p.m. Eastern on Monday – Friday, excluding holidays. If you are located outside of the United States, you should first contact your distributor or dealer directly with any issues.

When contacting Technical Service, please have the kit or part # ready, along with the make, model, and year of the vehicle. You may also need to provide details, such as 2WD/4WD or if the vehicle has been lifted or lowered from stock height.

If you have a warranty concern, please include in your email a detailed description of the situation, a photo(s) of the issue, and your contact information, including ship-to address.

**WARRANTY COVERAGE\***— The Ride-Rite™ kits, components, and accessories are warranted against defects in workmanship and materials. This warranty does not cover service or labor charges, neglect...to the product.

### **PERIOD OF COVERAGE:**

- |   |  |
|---|--|
| • Ride-Rite air springs – Lifetime Limited  | • Work-Rite load assists – 2 Years Limited                                       |
| • Sport-Rite air springs – Lifetime Limited | • Air-Rite accessories – 2 Years Limited   |
| • Coil-Rite air springs – Lifetime Limited  | • Brackets, hardware, fittings, air line, and other components – 2 Years Limited |
| • Level-Rite air springs – Lifetime Limited |  |

**HOW TO MAKE A WARRANTY CLAIM** — If you purchased your air springs in the U.S. or Canada and believe you have a part with a warrantable defect, call Firestone directly at 1-800-888-0650.

International customers should contact their distributors or dealers directly with any problems.

(\*) Please refer to the “Firestone Limited Lifetime Air Spring Warranty” for details, terms, and conditions.

## **FIRESTONE LIMITED LIFETIME AIR SPRING WARRANTY**

Firestone Industrial Products Company LLC ("Firestone") warrants that its Ride Rite Air Spring Assembly will perform according to the manufacturer's specifications for as long as the vehicle on which the system was originally installed is owned by the original retail purchaser. This limited warranty does not include installation or other service charges for replacement.

### Warranty Period

The Air Spring is warranted for as long as the original purchaser owns the vehicle on which it was originally installed. The fasteners and upper and lower brackets which accompany the air spring are warranted for a period of twenty-four (24) months or 24,000 miles whichever occurs first. This warranty begins on the original retail delivery date.

### What is Covered

Any implied warranties are limited in duration to the coverage period of this warranty (some states do not allow limitation on how long an implied warranty lasts so the above limitation may not apply to you). This Warranty runs in favor of the original retail purchaser when the Ride Rite Air Spring Assembly is used under normal operating conditions according to Firestone's specifications and installed on the appropriate application. This warranty does not apply to Ride Rite Air Spring Assemblies that have been improperly applied, improperly installed, used in racing or off road applications or used for commercial purposes. In addition, the warranty will not apply to products which have not been maintained and serviced according to the instructions that accompany the air spring assembly. The consumer will be responsible for any costs incurred in removing the product from the vehicle and the cost to return the air spring assembly to the dealer or installer from which it was purchased. If it is determined that the Ride Rite Air Spring Assembly failed as a result of a manufacturing defect, Firestone will repair or replace, at its option, any product or components subject to this warranty. You should retain a copy of your contract with your installer and your receipt as proof of the date of installation. This warranty is non-transferable and is not assignable in any way.

**Firestone specifically excludes any obligation for consequential damages or incidental expenses including claims for loss of use of the product, loss of time, inconvenience, or commercial loss. This warranty gives you specific legal rights. You may also have other rights that may vary from state-to-state. Some states do not allow limitations on how long an implied warranty lasts or allow the exclusion or limitation of incidental or consequential damages. The above limitation or exclusion may not apply to you. There are no warranties, express or implied, including implied warranty of merchantability and fitness which extend beyond this warranty.**

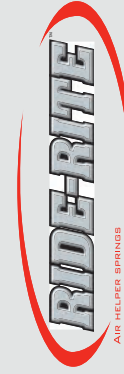

**Firestone**  
**World's Number 1**  
**Air Spring.**



FIRESTONE INDUSTRIAL PRODUCTS COMPANY